

Operating instructions for Evaporator TCE-BSC and variable power supply unit

3-4 cell evaporator

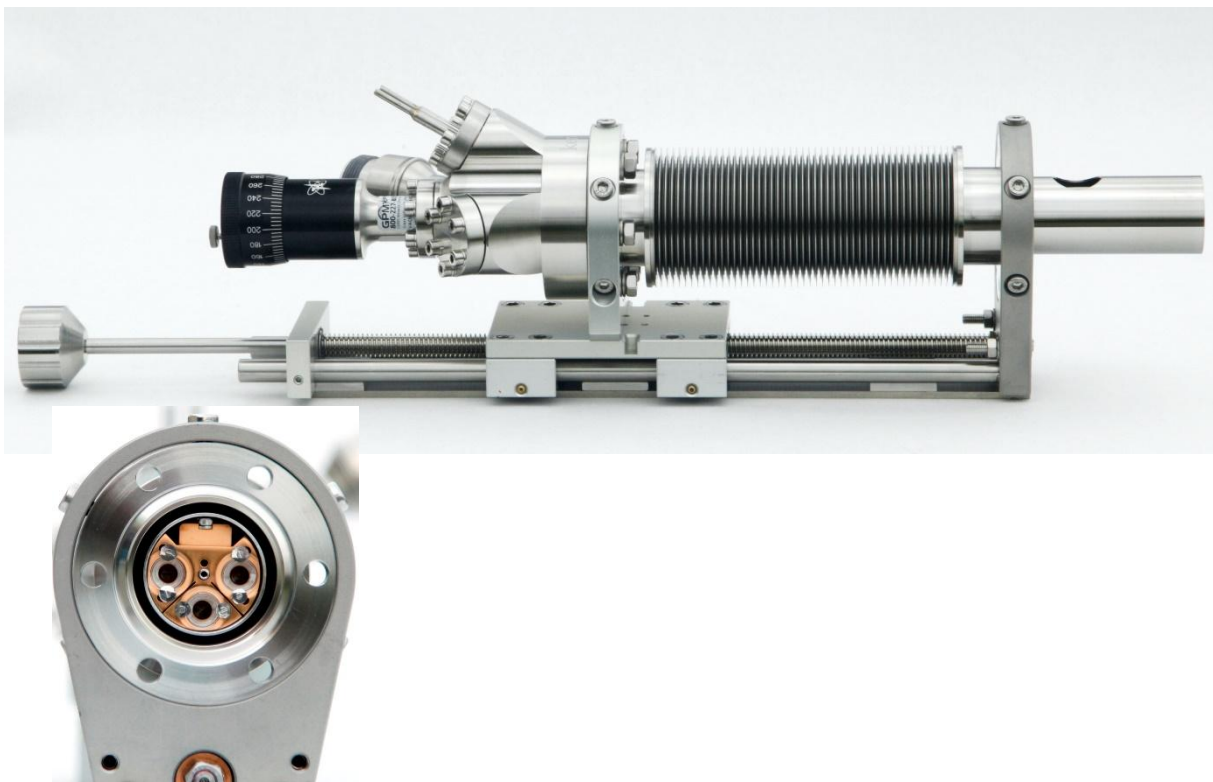

kentax.de | .eu
UHV equipment

Kentax GmbH
Wertstrasse 20e
30926 Seelze
Germany

Phone: +49 (0) 5137 9078 84
Fax: +49 (0) 5137 9078 86
E-Mail: info@kentax.de
Internet: www.kentax.de

January 2026

Table of contents

1	Evaporator TCE-BSC	page 4
1.1	Description	page 4
1.2	Filling of the crucibles	page 5
1.3	Crucible exchange	page 5
1.4	Flanging	page 7
1.5	External connection diagram	page 7
1.6	Cooling	page 8
1.7	Baking out	page 9
1.8	First start-up	page 9
1.9	Temperature behaviour	page 9
2	Variable power supply unit	page 10
2.1	ENDA EPC9513	page 11
2.2	Example of a setup	page 13
Appendix		
	How to use the mounting plate	page 15

1 Evaporator TCE-BSC

1.1 Description

The three cell evaporator has been designed especially for materials with a low sublimation temperature. For such substances, the crucibles must have a low thermal capacity so that the system time constants do not become too high. Heating is done by tungsten coils as it is impossible to use an electron impact heating when handling organic substances. For stoichiometric sublimation, two crucibles can be used simultaneously (provided that the control devices are designed accordingly).

The evaporator can be locked out for substance change without breaking the vacuum of the UHV chamber. The retraction mechanism (170mm stroke) makes it possible to adjust the distance between the crucible and the surface.

Thanks to the size of the crucible (filled with $\sim 0.1 - \sim 20\text{mm}^3$), film growth from the sub-monolayer up to the multilayer regime is possible using this evaporator.

The positions of the crucibles are shown in Fig. 1a).

The shutter has four holes (Fig. 1b) which allow to open one, two or three crucibles at a time according to the requirement.

Depending on the position in which the evaporator is mounted to the UHV chamber, completely open crucibles or partly open crucibles must be used. With the crucibles shown in Fig. 1d) an additional spring is required. As illustrated in Fig. 2 the two crucibles causes different leaving angles and also different distribution of kinetic energy of the molecules.

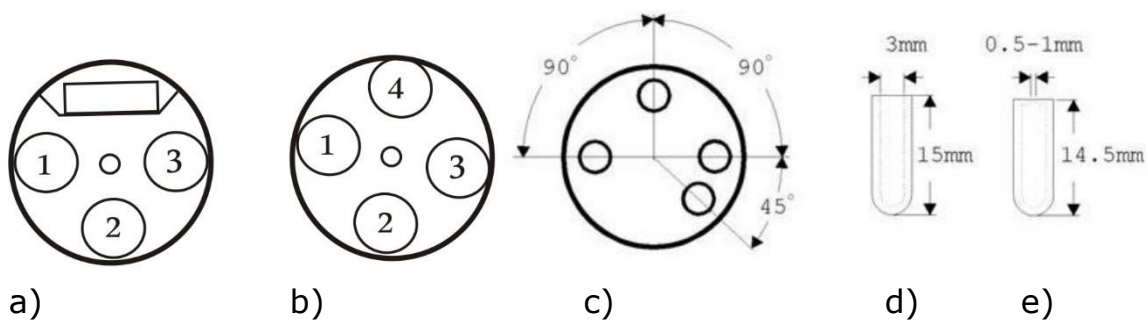

Fig. 1 Position of the crucibles (UHV view) 3-cell a), 4-cell b), Shutter c), open crucible d), and partly closed crucible e)

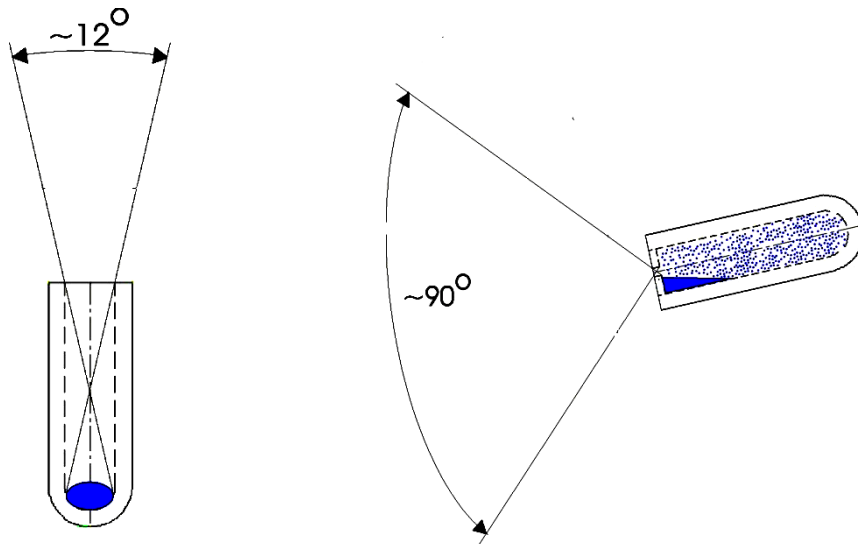

Fig. 2 Angle of emission of the two kinds of crucibles

1.2 Filling of the crucibles

The crucibles can be filled using a capillary funnel or a folded aluminium foil. **Before re-introducing the crucibles there must not be any substance on the outside or on the edges of the crucibles.**



a)

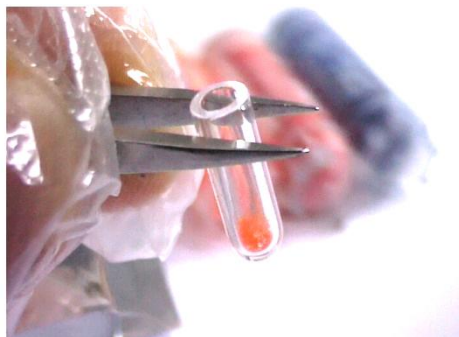

b)

Fig. 3a) The crucible can be filled with material by using clean aluminium foil.

1.3 Crucible exchange

When remounting the crucibles, make sure that only a small force is applied to the quartz heater. Otherwise, the quartz heater could be damaged. Please apply only a very small torque to the M1 screws (red and blue arrows in Fig. 4) to move the support bow if the evaporator is to be operated in a hanging position.

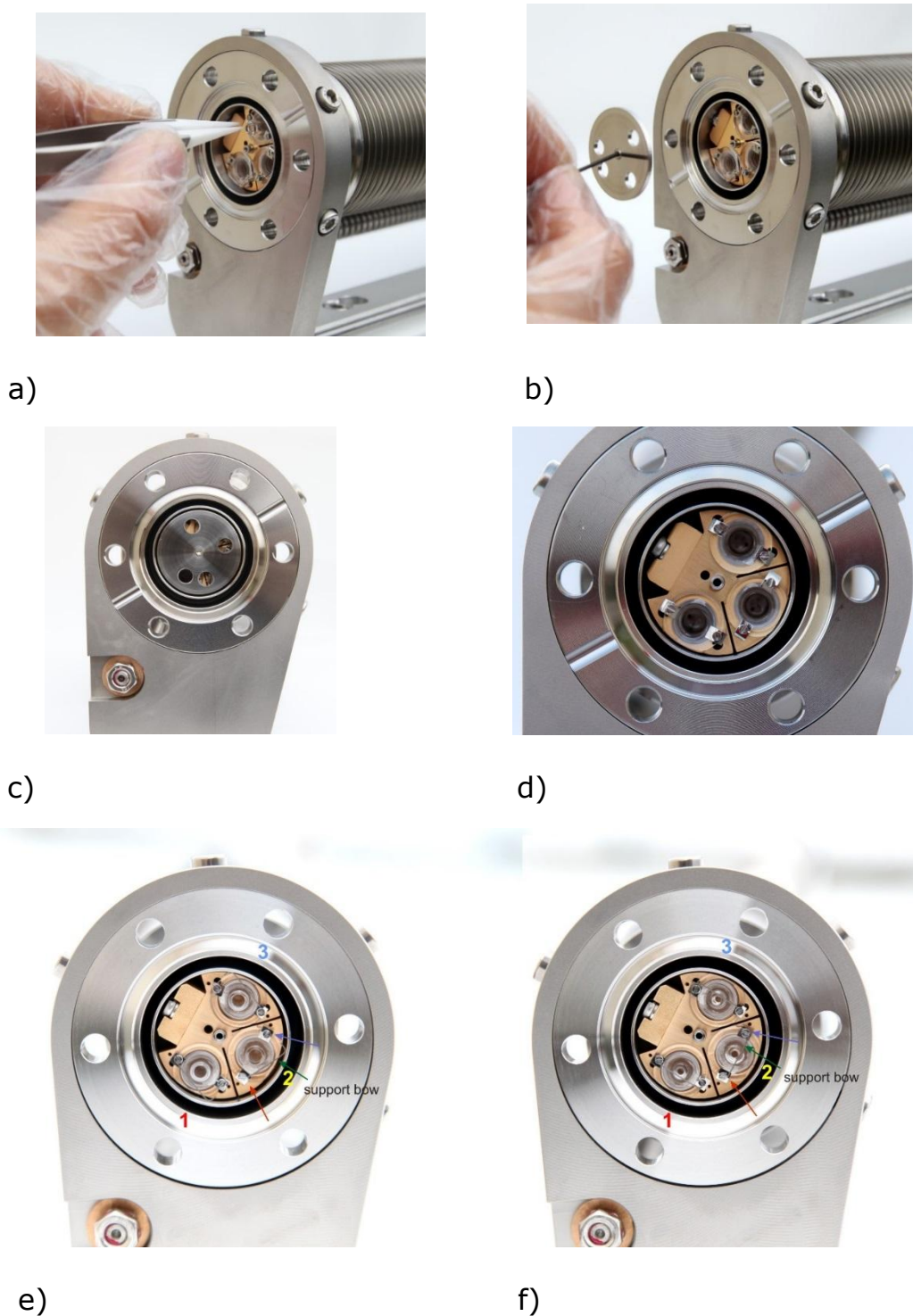

Fig.4 Removing of one crucible a), and mounting of the shutter b). Image c) shows one open crucible, d) standard version for normal operation without support bows (for standard crucibles without aperture). Image e) shows special version with support bows, but use with crucibles without aperture. In the case of hanging operation (special version), the crucibles (with aperture) are fixed by support bows, which are mounted with two M1 screws f). The left screw (red arrow) is use as an axle, the right screw (blue arrow) is used to fix the bow. Please apply only a very small torque when tightening the screws.



a)



b)

Fig.5 The crucibles are first cleaned with a lint-free cloth a). When using partly closed crucibles, rinsing should be done by means of a squirt b). In a second step, ultrasonic cleaning in acetone and heating with an electric dryer can be applied.

The crucible can be inserted directly using a glove-covered hand.

The crucible (Fig. 1c) juts out about 1mm and in this position, it touches the thermo elements directly.

After mounting the shutter, please note down the orientation in relation to the mechanical rotary feedthrough for future reference.

1.4 Flanging

The evaporator equipped with the open crucible (Fig. 1c)) must be mounted in such a way that the crucibles are below the horizontal plane.

1.5 External connection diagram

Electrical connection should be done according to the inscriptions or the colours of the plugs (Fig. 6). If you have a RS485 Interface, Pin 2 is RXD – Receive Data(+), Pin 3 is TXD – Transmit Data(-) and Pin 5 is COM.

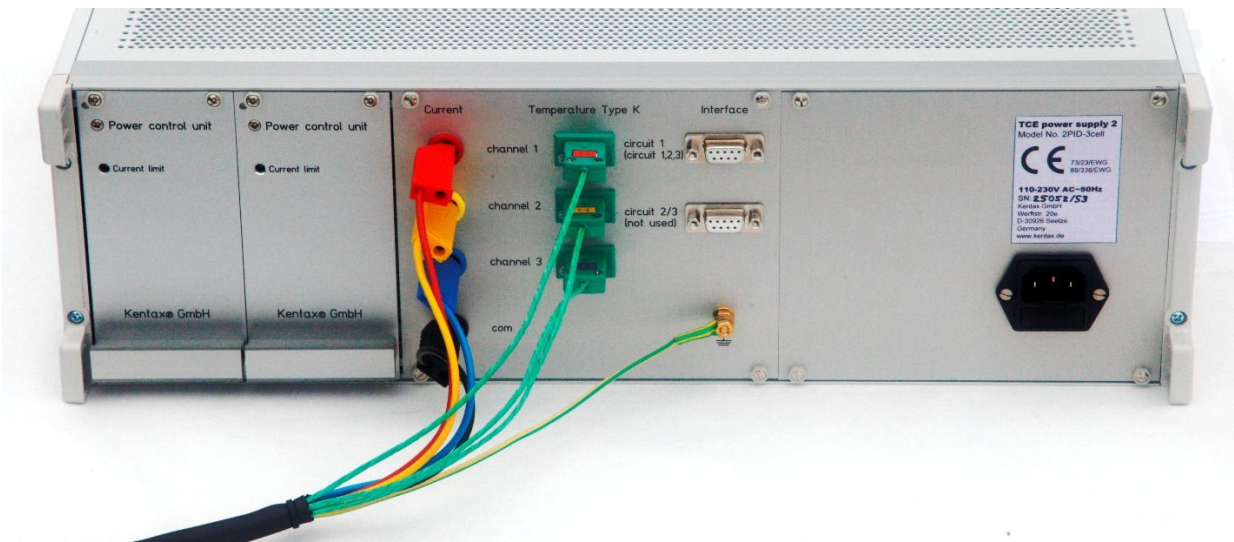

Fig. 6 Electrical connection of the power supply

If you wish to connect other power supplies than the included, the pin assignment of the feedthrough is given in Fig. 7. K type thermocouples (Ni95/(Al+Mn+Si)5-Ni90/Cr10) were used.

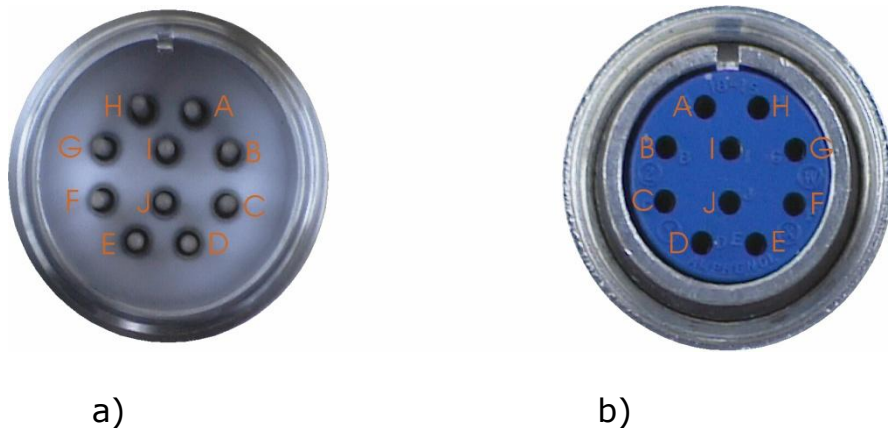

Fig.7 a) Feedthrough seen from the front (exterior view), b) Plug. A, B, C, (D) current for crucible 1, 2, 3, (4). I common use. E, F, G, (H) temperature measurement for crucible 1, 2, 3, (4). J common use.

1.6 Cooling

Cooling can be carried out by using cold water, liquid or cold gas nitrogen. The cooling tubes (outer diameter 3mm or 5 mm) can be attached by silicon hose.

We recommend low-pressure water cooling with a 5l-10l bucket (primary circuit) or in a secondary circuit. A water flow of 100ml/min, 0°C-22°C is sufficient. In the event of an accident, only a limited amount of water can escape.

1.7 Baking out

Usually the bellows and the multiplex flange are baked out to max. 200°C with a heating tape and an Al-foil. The compact z-travel contains adjustable high-temperature plain bearings.

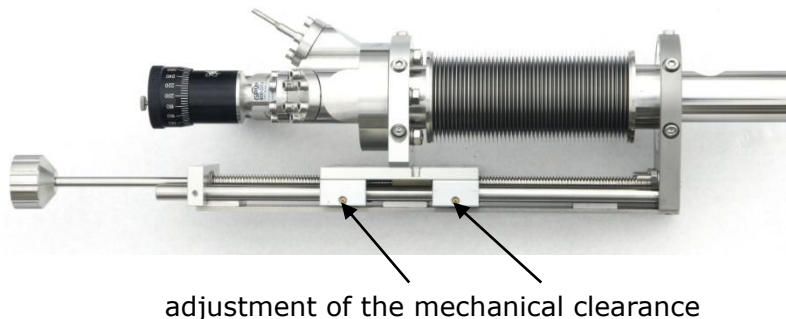

1.8 First start-up

After the evaporator has been mounted to the UHV system, electrical connection (chapter 1.5) is complete and the pressure is below 5×10^{-5} mbar (**Please make sure that potentiometer L is set to 0**), the evaporator can be started.

After setting the desired temperature (pressing up or down arrow key), the maximum load (potentiometer L) can be increased (for example, setting the potentiometer to 1.4 fits to a temperature of 250°C).

During the first start-up, the evaporator should be run below the sublimation temperature of the substance for some time. In case the substance contains solvents, the temperature must be increased slowly as otherwise, the substance might be expelled.

1.9 Temperature behaviour

Normally, the temperatures required for the sublimation of organic substances are between 30 and 600 °C. Higher temperatures are not useful for organic material, as they would inevitably lead to fragmentation of the substances.

Nevertheless, the evaporator is designed for higher temperatures (850°C, 950°C with additional shielding) so that, for example, an insulating layer can be produced.

Important temperatures of an evaporator are the temperature of the

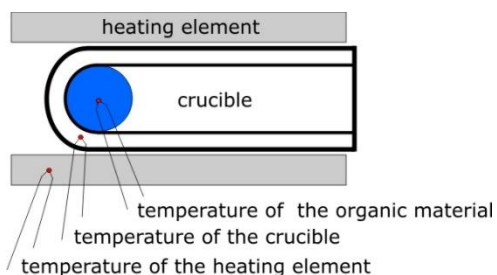

heating element, the crucible and the material to be sublimed.

Because of the interchangeability of the crucibles, there is no temperature measurement there as well in the position of the organic material.

These three temperatures result from thermal coupling through heat

conduction and infrared radiation.

- a) At low temperatures 30°C-100°C, the crucible and the organic contents take up the temperature from the heating element with a delay (e.g. 10 min at 100°C). This is because the crucible is heated only by thermal conductivity.
- b) In the lower temperature range (30°C-250°C), the material temperature best follows the temperature of the heating element.
- c) At higher temperatures of the heating element, the temperature of the substance can be higher than the indicated temperature. The delayed temperature acceptance is a few minutes.

2 Variable power supply unit



Fig. 8 Front view of the two kinds of power supplies

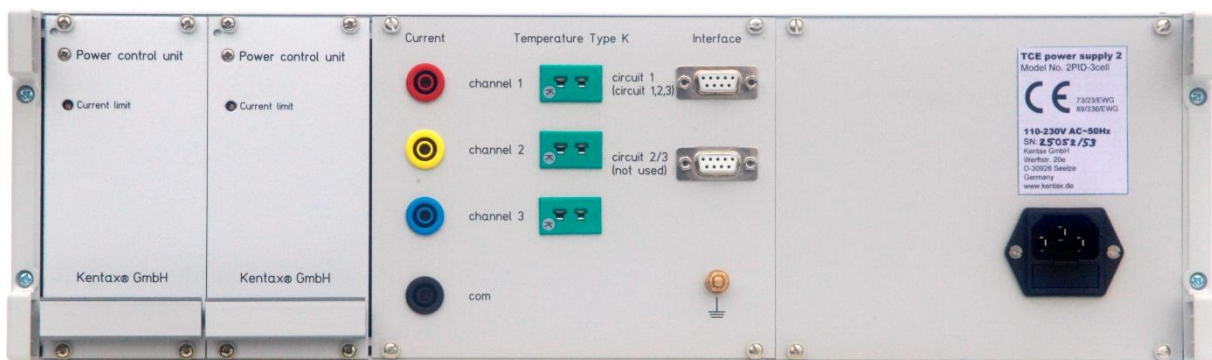
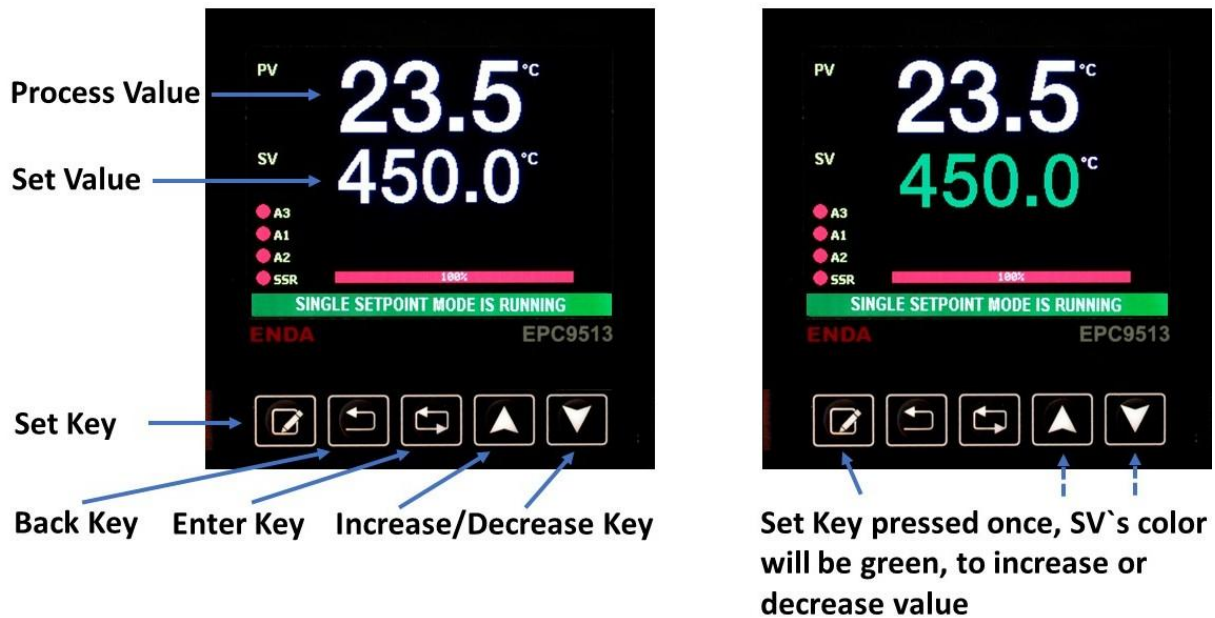

Fig. 9 Jacks at the back of the variable power supply unit. On the left side, the power supply has circuits for each PID channel with an adjustable current limit (c. lim.).

The variable power supply unit consists of a commercial microprocessor-controlled PID controller and an analogue output element driving the sources. An additional load-limit changer (potentiometer L) impedes that the source is accidentally activated with maximum current due to an operating error of the PID controller. Especially by setting the load-limit changer to 0, it is ensured that no current reaches the device when it is being connected. **After operation, the load-limit changer should be set to 0.**

2.1 The ENDA EPC9513

The first image show the ENDA EPC9513 at its operation level (LEu1) and how to change the desired temperature.



The first line (PV) shows the actual temperature in °C. The second line (SV) show the desired temperature. The red line below shows the output level of the PID.

In the lower menu bar the parameters or configurations values can be changed.

The values preset by Kentax are shown below:

The values of the configuration level can be accessed by holding the button (Enter Key) in the centre for a short time. The display jumps to the configuration page. The individual levels can be selected at this level using the increase/decrease key (up or down arrow).

If "Configuration Page" is selected, press the button in the middle again to access the menu for editing.

Up and down arrows allow you to navigate in the menu field. The value that can be changed is highlighted in red.

If you press the Set Key button, the colour changes to green and the value can be changed using the up and down buttons. Press the Set Key button again to highlight the field in red again.

Press up or down to jump to the next tab in the respective menu. If the values are set, press the second button from left to return to the configuration level or wait a little bit.

The Input Configuration Page selection is shown as an example

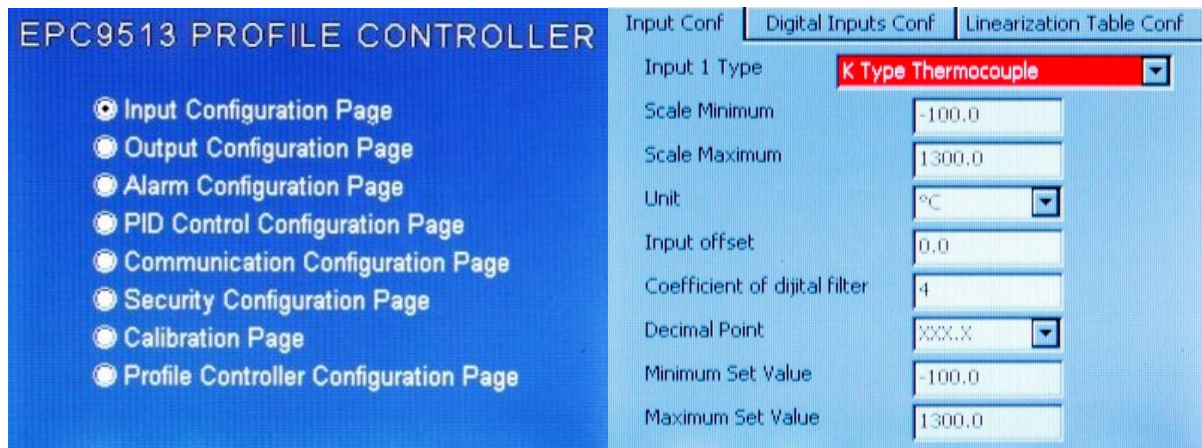

The values of the Output Configuration Page and PID Control Configuration Page are:
 (These are values for the average temperature range with values for Derivative Time of 0.0)

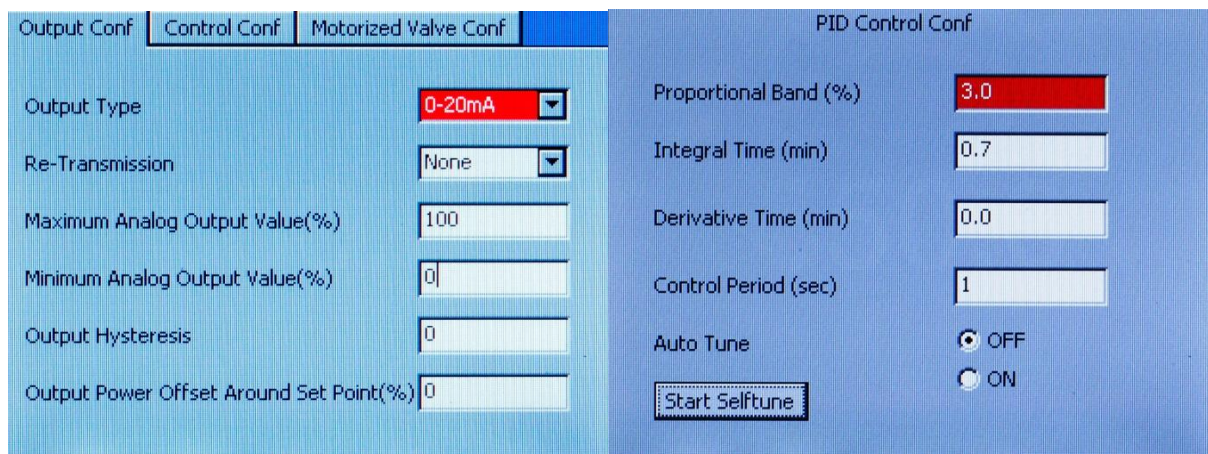

Profile Controller Configuration Page were set:
 (The upper menu line can be selected by pressing the centre Enter Key)

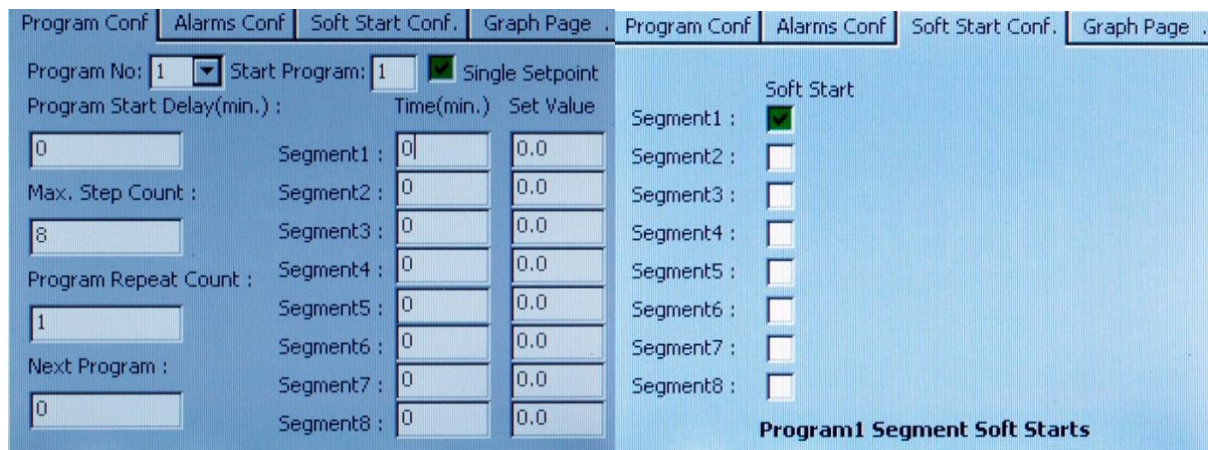

For a new setpoint temperature that differs significantly from the previous one, the values in the table (or interpolated values) can be used (input in PID Control Conf *).

The PID settings can be determined automatically using Selftune and Auto tune. At the start, the actual value must be 60% below the target value. The Derivation Time input should be set to 0.0, as the characteristic curve of the heating elements is non-linear.

2.2 Example of a setup

Tab.1: Example of a setup of the 3 cell TCE BSC evaporator. The values shows real measuring without crucible and setup values (data from May 2025).

Columns with **bold numbers** are easy to read from the front of the power supply unit.

Temp. [°C]	Potentiometer L	Start voltage [V]	Start current [A]	Start power [W]	Equilibrium power [W]	P	I	D	output level [%]
20	0.20	0.33	0.35	0.12	0.02	0.2	0.9	0	45
30	0.30	0.67	0.65	0.44	0.06	0.2	0.9	0	40
50	0.40	0.72	0.70	0.50	0.16	0.2	0.8	0	59
100	0.60	1.09	0.85	0.93	0.38	1.4	0.8	0	66
150	0.84	1.57	0.95	1.50	0.71	1.7	0.8	0	65
250	1.35	2.61	1.15	3.0	1.52	1.1	0.7	0	69
350	2.0	3.92	1.40	5.5	2.96	1.4	0.8	0	72
450	2.7	5.33	1.60	8.53	5.3	1.7	0.6	0	77
550	3.7	7.4	1.75	12.9	8.3	3.0	0.4	0	78
650	4.8	9.8	2.20	21.6	12.6	4.4	0.4	0	74
750	5.9	12.0	2.35	28.2	20.2	5.2	0.4	0	83
850	7.5	14.7	2.50	36.7	30.9	8.6	0.4	0	85

Data from 2025 (enda PID EPC9513) partially interpolated

The PID default setting is $P_d=3.0$, $t_i=0.7$, $t_d=0.0$. It should give usable results in the temperature range 150°C - 450°C.

Since the heating inserts are partly handmade, the characteristics vary and sometimes make it necessary to adjust the electrical parameters. Detailed information on manual setting can be found in the ENDA manual (on the supplied USB stick).

Depending on the desired temperature rise time, other settings also lead to stable control.

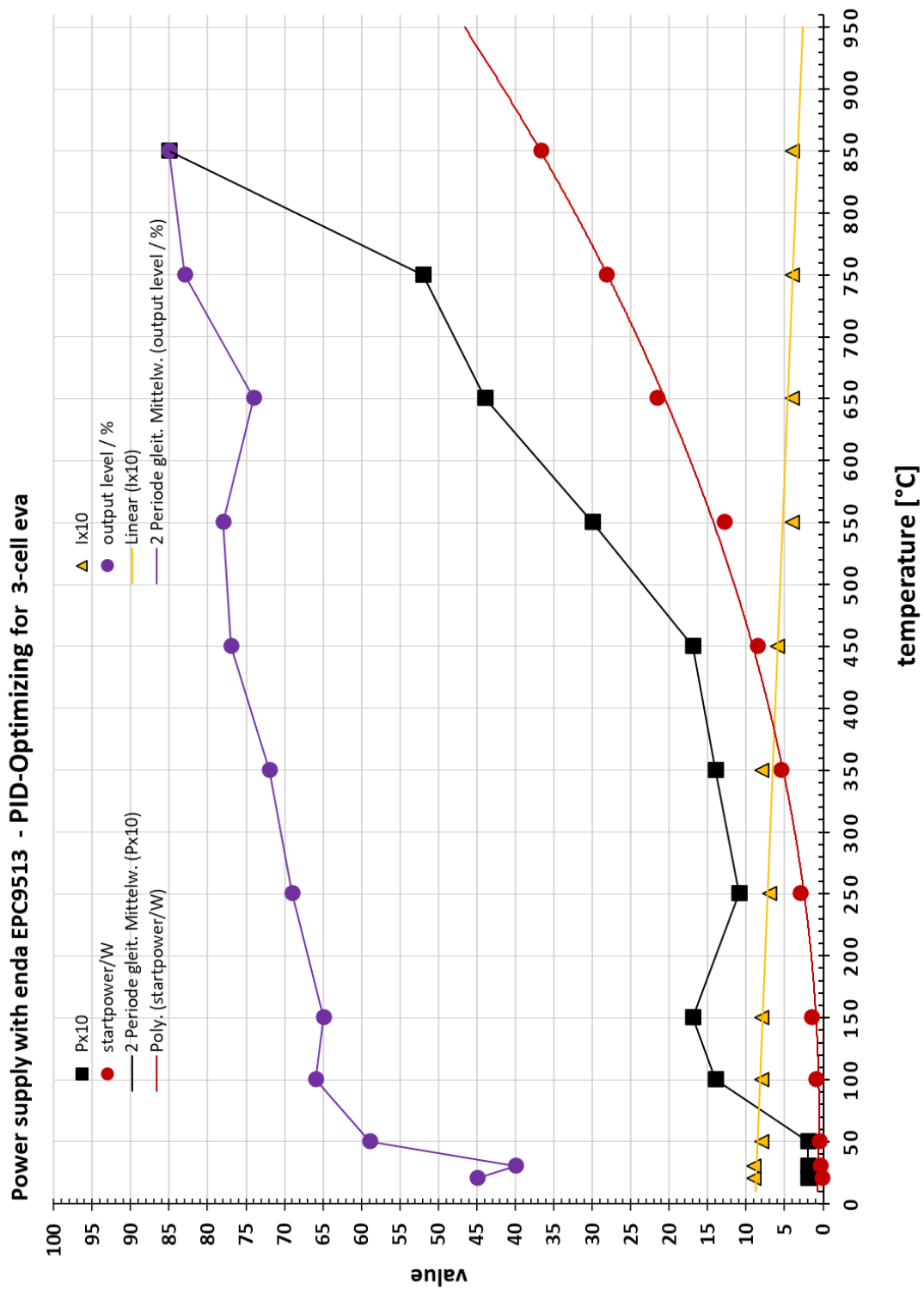

The diagram shows the relevant parameters from Tab.1 in visualized form

How to use the mounting plate

The supplied mounting plate should help a little to prevent the copper seal and the filling material from falling out of the crucibles.



The two rods are inserted into the holes on the left-hand side. The evaporator only rests on the right-hand side. The table is asymmetrical to prevent the evaporator from tipping over when using evaporators with a pump-down valve.